

Survey on the Societas Europaea
September 2003

Annex 5 - France

FRANCE

THE TAX TREATMENT OF A SOCIETAS EUROPEAS IN FRANCE

GENERAL INTRODUCTION

French tax law provides for a favourable tax regime, which covers qualifying mergers, divisions and transfers of assets. When the favourable regime does not apply, restructuring operations may lead to a winding-up of the company, having the consequences of immediate taxation of income, reserves and capital gains in the hands of the acquiring company and in the hands of the shareholders of the transferring company. The special merger regime is an optional regime, providing for the tax-neutrality of the restructuring operation. It remains conditional upon compliance with the law and in some instances upon prior approval from the French tax Authorities. This regime was modified several times over the years and more recently to comply with the European Directive 90/434/EEC of 23 July 1990 (hereinafter the EC Merger Directive).

1. *General*

The French tax system is based on the principle of territoriality. Resident companies are subject to corporate income tax on income derived from enterprises operating in France or enterprises the taxation of which is attributed to France under a tax treaty. Therefore, subject to various treaty provisions, business income derived from foreign operations is not assessable to French tax. In this respect and along the report, restructuring operations affecting a foreign permanent establishment of a French company and foreign subsidiaries will generally not have any corporate tax effects in France.

Exceptions to the territoriality rule include the consolidation tax regime¹ (upon prior approval of the tax authorities), the CFC legislation² and temporary tax-free provisions for investment abroad³.

1.2. The favourable regime

Scope of the favourable regime

The favourable regime covers a broader scope than the one provided by the EC Merger Directive, and applies to operations (mergers, division and partial business transfers) between French companies, between French and European (EU) companies, and between French and non-EU companies, except those involving companies whose registered office is located in a state or country which has not signed a tax treaty with France containing an administrative assistance clause aimed at fighting tax fraud and evasion. French companies are those incorporated under French law or which have their real seat

¹ The tax authorities may permit the consolidation of income of a parent company with that of local and foreign subsidiaries in which it holds a 50% share or more.

² Under Art. 209 B, a resident company may be assessed to tax on a proportional share of the income realized by (and deemed received from) a subsidiary or permanent establishment located in a low-tax jurisdiction.

³ French companies (and permanent establishments of foreign companies) may set up a temporary tax-free provision in connection with the establishment of foreign branches and subsidiaries (Art. 39octies A CGI).

in France. In this respect, the nationality of the shareholders and the location of activities are not taken into account.

Sources of law

The last changes in the favourable regime were introduced by the Finance Law 2002 (Law no 2001-1275, 28 December 2001). The French favourable regime is codified in the General Tax Code under the following articles:

- 210 A to 210 C which deal with the favourable corporate income tax regime applicable to mergers, divisions and partial business transfers;
- 38 (7) *bis* which deals with the exchange of securities as a result of a merger or division; and
- 112, 115 and 120 which deal with the definition of distributable income and the tax regime covering securities received in consideration for a merger, division or partial business transfer.

1.3. Eligibility to the favourable regime

As a general rule, the favourable regime applies only if the following conditions are met:

- the companies involved in the restructuring operation are liable to corporate income tax⁴;
- in cases where a French company transfers its assets to a foreign company, a prior approval from the tax authority is required⁵; and
- the transfer of assets is compensated by the allocation of shares or units.

Prior approval

As, a general rule, the law introduces criteria for the granting of approval whenever a French company transfers assets or securities to a foreign company. Further, prior approval must be obtained for the transfer of losses from the transferring company to the receiving one. Prior approval (*agrément*) is a form of administrative authorization required for the application of the tax-neutral regime to many restructuring operations. It takes the form of authorization granted, generally by the Budget minister (or the Regional Director of taxes where the decentralization procedure applies), before the operation for which prior approval is requested. Prior approval either confirms the applicability of tax relief in a particular situation or, where the conditions required to benefit from the tax relief are legally fixed, confirms that these conditions are satisfied. French law provides

⁴ Art. 210 C (1) of the CGI

⁵ Art. 210 C (2). If in principle the favourable regime applies to mergers, divisions and partial business transfers without distinguishing with the nationality of the companies involved, an administrative approval must be obtained beforehand in instances where transfers of assets to foreign companies are realized by French companies. The granting of conditions for approvals authorizing application of the favourable regime to asset transfers to foreign companies are now laid down in Art. 210 B (3) and are no longer discretionary.

only for mandatory prior approval⁶ with respect to the favourable mergers regime. Mandatory prior approval (*agrément de droit*) is granted in situations where the law fixes the conditions required and leaves to the authorities only the power to decide whether these conditions are satisfied. Therefore, any refusal must be justified and may be challenged before the courts.

1.3.1. Prior approval on qualifying restructuring operations

Prior approval may be granted provided that the assets are not effectively transferred abroad. It is therefore a legal requirement that the assets remain on the balance-sheet of a French permanent establishment of the receiving company. The transferring company must apply for the prior approval. The criteria for the granting of approval are as follows⁷:

- the transaction has a valid economic justification;
- the principal aim or one of the principal aims of the transaction is not tax fraud or evasion; and
- the transaction terms and conditions ensure the future taxation of the capital gains whose taxation is deferred.

1.3.2. Prior approval on transfer of losses

Article 85 of the Finance law 2002 removed the discretionary character of this authorization. The new conditions for approval are set out in Art. 209 II of the CGI⁸. Approval must be granted if the following conditions are met:

- the restructuring falls within the scope of the favourable mergers regime (as described in the introduction) ;
- the restructuring is economically justified and is not primarily motivated by tax reasons; and
- the receiving company makes the commitment to retain the loss-making activity for at least 3 years.

The amount of losses that can be transferred is limited to the greater of (i) the gross book value of the fixed tangible and intangible assets (excluding financial assets) used in the business or (ii) the transfer value of these assets. Financial and non-operating assets are not included when determining this ceiling. In order to increase the amount of losses which may be transferred it will sometimes be necessary to record, in the account of the receiving company, intangible assets transferred, such as acquired goodwill, at real value.

⁶ The practice of discretionary approval with respect to the favourable mergers regime has been abolished by the Finance Law 2002. New Article 210 C (2) provides that transfers of assets to foreign companies are subject to prior approval under the provisions of Art. 210 B (3).

⁷ These criteria are provided by Art. 210 B

⁸ For further details on the transfer of losses, see Guideline of 21 August 2002 (BOI 13-D-2-02) .

CASE 1

Merger by acquisition

(Art. 2 par. 1 jo. Art 17 par. 2(a) Reg. 2157/2001)

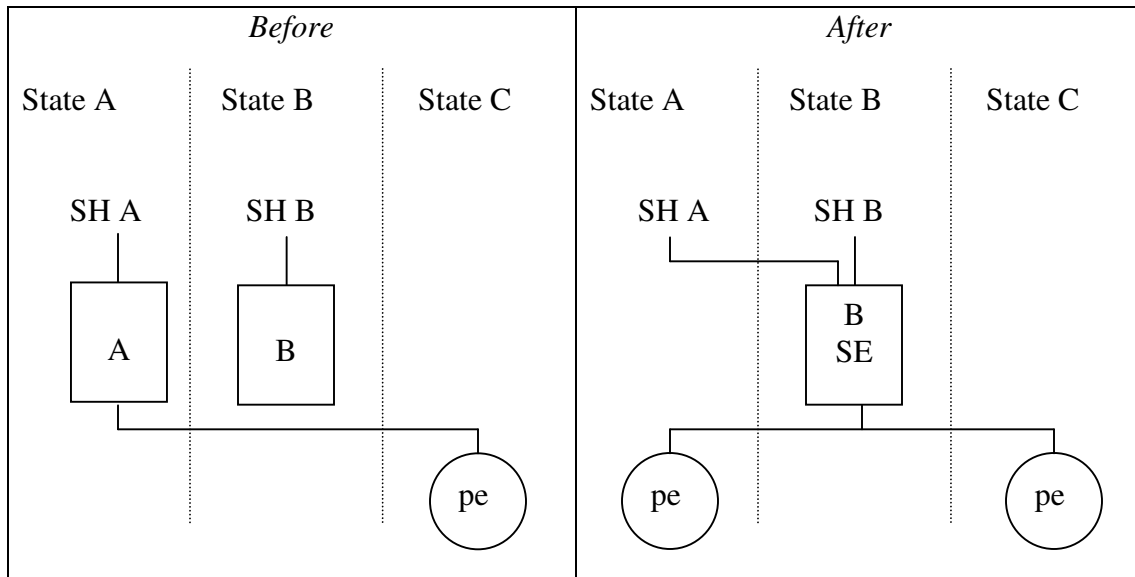

Facts and assumptions

- SH = shareholder(s), resident in the respective country in which SH is situated
- A and B are existing companies
- A and B are public limited-liability companies (see Annex I to Reg. 2157/2001)
- State A, State B, and State C are EU Member States
- A:
 - formed under law of Member State A
 - registered office in Member State A
 - head office in Member State A
 - has a permanent establishment in Member State C
- B:
 - formed under law of Member State B
 - registered office in Member State B
 - head office in Member State B
- B SE:
 - registered office in Member State B
 - head office in Member State B
 - will be covered by the EC Merger Directive

Transactions

- A:
 - transfers all assets and liabilities to B
 - in exchange for shares in B (and cash payment if any, not exceeding 10% of nominal value of shares to be issued) issued to shareholder(s) of A
 - will be wound up without going into liquidation

- B / B SE:
 - as the acquiring company, B will take the form of an SE when the merger takes place (Art. 17 Reg. 2157/2001: “In the case of a merger by acquisition, the acquiring company shall take the form of an SE when the merger takes place”. Consequently, there are in fact two transactions: 1) the merger and 2) a transformation of a public limited-liability company into an SE. With regard to the transformation, see also Case 9.
 - will be regarded as public limited-liability company governed by law of Member State B

Questions

1. Assume Member State A is your country

Tax implications in France of the creation of an SE under the operation of merger by acquisition

Introduction

The application of the favourable mergers regime to restructuring operations is conditional upon several requirements.

Scope

First, the tax administration verifies if the restructuring operations falls within the scope of the definition provided in Art. 210-0-A-I of the General Tax Code (CGI). In this respect, the favourable regime for mergers applies to operations where “one or more acquired companies transfer, consequent to and at the moment of their dissolution without liquidation, all their assets to a pre-existing acquiring company in return for the allotment of securities in the acquiring company to the shareholders and, if necessary, a payment not exceeding 10% of the nominal value of the securities⁹. In this respect, the merger by acquisition of case 1 falls within the scope of the definition. Mergers involving the transfer of assets abroad are subject to a prior approval from the French tax authorities (see Introduction 1.3.1).

⁹ The tax administration issued a Guideline on 25 October 2002 (BOI 4 I-2-02) on the application of the favourable regime, which interprets the legal definition of mergers.

Upon approval, the receiving company must subscribe to the conditions of the favourable mergers regime as provided by Art. 210 A of the CGI (see answer 1 (a)). The permanent establishment of the receiving company will effectively abide by the restrictive conditions imposed by the tax authorities, for the account of the receiving company.

1.a. Tax treatment of capital gains

Provided company A is eligible to the favourable mergers regime, capital gains on mergers are exempt from corporate income tax. The French tax administration requires that the operation leads to the creation of a permanent establishment in France and verifies that all the assets and liabilities from the transferring companies are taken over by the permanent establishment of the receiving company.

The tax-neutral regime applies only if the receiving company undertakes, in the transfer agreement, to¹⁰:

- take over various items from the transferring company's accounts, including reserves not taxed at the time of the transfer or any long-term capital gains reserves (which were taxed at a lower rate upon realization provided they are booked to a special reserve);*
- include in its income capital gains realized by the transferring company and benefiting from a tax deferral prior to the transfer;*
- add to its taxable income within a period of 5 years capital gains¹¹ on depreciable assets that were exempt during the transfer (see below);*
- add to its taxable income over a period of 15 years those capital gains on buildings and connected assets that were exempt at the time of the merger; and*
- compute future capital gains or losses on the disposal of non-depreciable assets included in the transfer by reference to the value of these assets in the books of the transferring company.*

Capital gains realized on the transfer of depreciable assets are taxed over several years (5 or 15 years depending on the assets) at the level of the receiving company and enables the receiving company to calculate depreciation related to such assets on the basis of the value attributed to them at the time of the merger.

Relief for depreciable assets

The technique used to grant relief is different from the roll-over envisaged by the Directive. The gains must be added to the receiving company's income in equal amounts over a maximum period of 5 years, or 15 years for real estate and similar assets. Tax is levied at the ordinary corporate tax rate. The disposal of a depreciable asset within that period would result in an immediate taxation of the receiving company with respect to any part of a capital gain on that asset which the company has not yet added to its

¹⁰ These conditions are provided by Art. 210 A of the CGI.

¹¹ The calculation of a capital gain or loss for a transferring company is the difference between the real transfer value of its assets and their value for tax purpose (net book value of the asset in question, i.e. the cost of this asset less depreciation, amortization or provisions.)

income. Alternatively, if prior approval has been granted for the transfer of losses of the transferring company, the receiving company may offset a capital gain on a depreciable asset against those losses.

If any depreciable assets included in the transfer show a loss, the tax authority accept that the receiving company may offset the loss against its own income with the limit of five-year carry-forward starting on the date of the transfer. Alternatively, the tax authority also accepts that the loss may be offset against the income of the transferring company. In both cases, the receiving company books the asset at its market value at the time of the transfer.

Depreciation may be deducted by the receiving company according to the expected life of the asset, determined according to accepted practice in the relevant economic sector. The expected life for depreciating the assets is determined as of the date of the transfer and may, therefore, be longer than the remaining expected life on the books of the transferring company. The receiving company may exercise the option available for new assets and depreciate according to the declining-balance method, multiplying the depreciation percentage by a multiple of 1.5, 2 or 2.5, depending on the expected useful life.

Long term capital gains

Unless they qualify for the reduced rate, capital gains realized in accounting periods opened on or after 1 January 1997 are taxed at the standard corporate income tax rate (plus surtaxes) in the same way as ordinary income.¹²

Capital gains qualify for the reduced rate (i.e. 19%) if realized on:

- *participation shares, i.e. shares qualifying for the participation exemption, shares acquired in the framework of a public takeover bid (OPA or OPE) and shares with an acquisition cost of at least EUR 22.8 million; or*
- *units and shares held for at least 5 years in qualifying venture capital investment funds or companies.*

Tax treatment of non-depreciable assets

Any capital gains or loss on non-depreciable assets (including non-fixed assets, e.g. inventory and portfolio securities) is simply deferred until the subsequent disposal of the assets. The general exemption applies to capital gains realized by the transferring company on inventories and financial assets, which must be booked at their fiscal value in the accounts of the receiving company. If the receiving company decides to book inventories and financial assets at their real market value, the favourable tax regime may still apply. For that purpose, the receiving company must add back to its profits realized during the financial year of the merger, the difference between the market value and the

¹² Until recently, long-term capital gains were subject to a reduced corporate income tax rate if booked to a non-distributed special reserve. Therefore, a distinction between short-term and long-term gains was essential. This is now less relevant since the application of the reduced rate has been drastically restricted and most capital gains are treated as ordinary income.

tax value of the assets and inventories which was accounted for by the transferring company.

Reintegration of capital gains

The receiving company takes over from the transferring company the obligation to add to its income capital gains realized before the transfer and subject to deferred taxation. This occurs, for example, if the transferring company received depreciable assets in a restructuring operation during the four years preceding the transfer. It also occurs if capital gains were realized in an expropriation, in which case taxation is spread over 10 years under CGI, Art. 39 quaterdecies (1) (ter).

1.b. Tax treatment of provisions and reserves

Roll-over relief is available if partly or wholly exempt provisions remain justified at the time of the merger¹³. In that case, the provisions are taken over by the receiving company. Reserves and provisions which can no longer be justified as a result of the restructuring operation may not be transferred to the receiving company.

1.c. Transfer of losses

Transfer of losses available for carry-forward

The losses suffered by the transferring company prior to the merger, including losses corresponding to deferred depreciation, may not be transferred to the receiving company unless prior approval has been granted by the Budget Minister or, in certain cases, the Regional Director of Taxes (CGI, Art. 209-II and Ann. IV, Art. 170 sexies). Conditions for approval are set out in para. 1.3.2 of the general introduction.

Transfer of the loss carry-back receivable

The transfer of loss carry-back is possible in the event of a merger, qualifying or not to the preferential regime. Prior approval is not required.

1.d.e and f. Tax treatment of the permanent establishment located abroad

Under the territoriality rule (see General introduction), assets connected with a permanent establishment located in Member State C are generally ignored for French tax purposes. Therefore, capital gains realized at the time of the transfer of assets of A's permanent establishment to Company B are exempt in France. By the same token, losses incurred by the foreign establishment may not be deducted from the taxable income of the transferring French company.

Tax effects for SH A in Member State A

French individual and corporate shareholders are not always taxable with respect to gains realized in the framework of a merger. Assuming there is no tax treaty between

¹³ CGI Art. 210 A (2)

France and the foreign country, France is entitled to tax the capital gains under the following principles (domestic tax rules), if the shareholder is a French resident.

1.g. Tax treatment of the French-resident shareholders of the transferring company

In a restructuring under the favourable regime, the allocation of shares by the receiving company is not treated as a distribution¹⁴. This provision avoids the triggering of any distribution tax, such as the précompte (equalization tax) or dividend tax. In this respect, French tax law follows the provisions of Art. 8(1) of the EC Merger Directive. Nevertheless, capital gains arising from the allocation of shares are subject to tax, unless the tax-neutral regime applies. Where the shareholders of the transferring company are entitled to relief with respect to the merger, this is provided by a simple roll-over in which the shareholder uses the tax value of his old shareholding in the transferring company for his new shareholding in the receiving company.

Taxation of French-resident corporate shareholder

Resident corporate shareholder SH A is normally taxable with respect to gains on shares in resident company A. Provided the conditions in the introduction of this case are met, corporate shareholder SH A qualifies for roll-over relief. Upon disposal, the following situations arise.

Gains upon the disposal of SE shares are taxable to SH A either in the standard corporate tax rate (33.1/3%) or, if the gains would qualify as a long-term gain, at the reduced rate of 19%.

Taxation of French-resident individuals

Ordinarily, resident individuals are subject to income tax at the rate of 26% (including social taxes on capital gains (whether realized on a substantial or non-substantial participation) but only if the aggregate securities transactions during the year exceeded EUR 15,000 (for 2003). In this case, the gain on the share exchange will be rolled-over, at the request of the shareholder, without a minimum holding requirement. The value of the exchange is ignored in determining the securities transactions volumes of the relevant year. The gains are taxable on the disposal of SE shares (same where the securities transaction volume of the relevant year is lower than the threshold, and in certain other circumstances), or, if the shares formed part of a substantial participation, if the shareholder emigrates from France (exit tax).

SH A is a French –resident individual entrepreneur

Individual entrepreneurs benefit from the same roll-over relief as corporate shareholders. Nevertheless, they remain taxed at the same tax rate as individuals (i.e. 26% including social contributions).

¹⁴ Art. 115-1 of the CGI.

1.h. Tax treatment of non-resident SH A

Tax treatment of foreign-resident corporate shareholders

Non-resident corporate and individual shareholders are generally not taxable on capital gains on shares in French companies unless the shares are attributable to a permanent establishment in France, or relate to French real estate, or represent a substantial participation.

Tax treatment of foreign-resident individual shareholders

For the two categories of individual shareholders (i and ii), gains realised on the disposal of shares in French real estate companies are taxable in France. A roll-over relief is available until the disposal of the shares provided the non-resident shareholder appoints a fiscal representative in France, liable to pay the tax on a future disposal.

2. Assume Member State B is your country

Tax effects for B and B SE in Member State B

2.a. Tax consequences upon the transformation

Company law aspects

Under the Regulation of 8 October 2001¹⁵, an SA or SARL may form an SE by means of a merger provided that the companies involved in the restructuring operation¹⁶ (i.e. at least two of them) are governed by the law of different Member States. Article 1844-3 of the French Civil Code stipulates that the regular transformation of a company into another legal form does not lead to the creation of a new legal entity. The company keeps its assets and liabilities, as under the previous legal form.

Under French Company law, a company may change legal form provided all the legal requirements of the new legal form are met (number of shareholders, minimum capital requirement, nomination of statutory auditors). For this purpose, the shareholders of a French stock company (SA or SARL) may have to increase the share capital to the minimum requirement of EUR 120,000¹⁷. According to Arts. 225 to 243 of the French Commercial Code, an SA may change its legal form provided that (i) it has been created for more than two years and (ii) the last two annual financial statements have been approved by the shareholders. The transformation of the SA into an SE will probably have to be approved by the shareholders, at a quorum to be determined by law. Furthermore, under Article 236-2 of the Commercial Code, if a merger takes place by the creation of a new company, the merger shall occur according to the rules pertaining to

¹⁵ Council Regulation (EC) No 2157/2001 of 8 October 2001 on the statute for a European company (SE), hereafter SE Regulation.

¹⁶ Art. 2 (1) of the SE Regulation.

¹⁷ Art. 4 (2) of the SE regulation.

the new legal form. The merger operation takes place when the new company (SE) is registered at the Registry of Commerce.

Tax law aspects

Upon the mergers, assets are transferred to company B at the book-value they had in company A.

Upon the transformation of legal form, the SE is liable to French corporate tax, like the former company B. Therefore, both companies are covered by the same tax regime. In this respect, the transformation of the legal form is a tax-neutral operation for the company B.

2.b. Attribution of value for tax purposes upon the transformation

The newly created SE takes over the assets and liabilities of the former company B at their net book value in the books of the former company B.

Tax effects for SH B in Member State B

2.c. Consequences of the transformation for SH B

The situation of the shareholders is not affected by with respect to the change of legal form. Upon the merger operation, there are in principle no tax consequences for the shareholders of the receiving company. However, since the capital of the receiving company may be increased (i.e. to meet the legal requirement under company law), the shareholding may dilute, which may have some tax consequences with respect to the participation exemption or the substantial participation criteria entitling to the long-term capital gains regime.

Further, if the former company B (i.e. new SE) holds a participation in company A, no securities have to be issued in consideration for any shares of company A which are already held by former company B (i.e. new SE). Capital gains upon this operation (Boni) may arise, resulting from the difference between the current value of the assets corresponding to the old shares and the net book-value of the old shares. These capital gains are exempt, provided the favourable mergers regime applies to the operation.

3) Assume Member State C is your country

Tax effects for A and B SE in Member State C with respect to its permanent establishment in Member State C

3.a. Tax consequences for company A

This merger operation results in a change of ownership of the French permanent establishment. Ordinarily, the operation is treated as a liquidation, leading to the immediate taxation of capital gains and of the income not yet taxed. In this respect, company A and its shareholders would be liable to tax.

Nevertheless, the tax authorities accept that the favourable mergers regime applies provided that the receiving company B takes, in the mergers agreement, the commitment to respect the requirements provided in Art. 210 A . Therefore, the permanent establishment of the receiving company B must:

- *include in its liabilities various items from the account of the permanent establishment of A (hereinafter PE A) , including reserves not taxed at the time of the transfer or any long-term capital gains reserves;*
- *include in its income capital gains realized by the PE A but benefiting from deferred taxation prior to the transfer;*
- *add to its taxable income within a period of 5 years capital gains¹⁸ on depreciable assets that were exempt during the transfer;*
- *add to its taxable income over a period of 15 years those capital gains on buildings and connected assets that were exempt at the time of the merger;*
and
- *compute future capital gains or losses on the disposal of non-depreciable assets included in the transfer by reference to the value of these assets in the books of PE A.*

In practice, the situation of the permanent establishment will remain unchanged if the net book value of the assets is taken over.

3.b. Tax treatment of provisions and reserves

Reserves and provisions which remain justified need not be taxed upon the merger but may be taken over in the books of PE B.

3.c. Transfer of losses

The losses suffered by PE A prior to the merger, including losses corresponding to deferred depreciation, may not be transferred to PE B unless prior approval has been granted by the Budget Minister or, in certain cases, the Regional Director of Taxes (CGI, Art. 209-II and Ann. IV, Art. 170 sexies). The conditions for approval are set out in Art. 209 II of the CGI¹⁹.

Transfer of the loss carry-back receivable

The transfer of loss carry-back is possible in the event of a merger, qualifying or not to the preferential regime. Prior approval is not required.

3.d. Transfer of losses

Under the merger tax regime, the transfer of losses is always conditional upon a prior approval, which is set in Art. 209 II of the CGI, as indicated in 3.c.

¹⁸ The calculation of a capital gain or loss for a transferring company is the difference between the real transfer value of its assets and their value for tax purpose (net book value of the asset in question, i.e. the cost of this asset less depreciation, amortization or provisions).

¹⁹ For further details on the transfer of losses, see Guideline of 21 August 2002 (BOI 13-D-2-02) .

CASE 2

Merger by formation of a new company (Art. 2 par. 1 jo Art 17. par 2(b) Reg. 2157/2001)

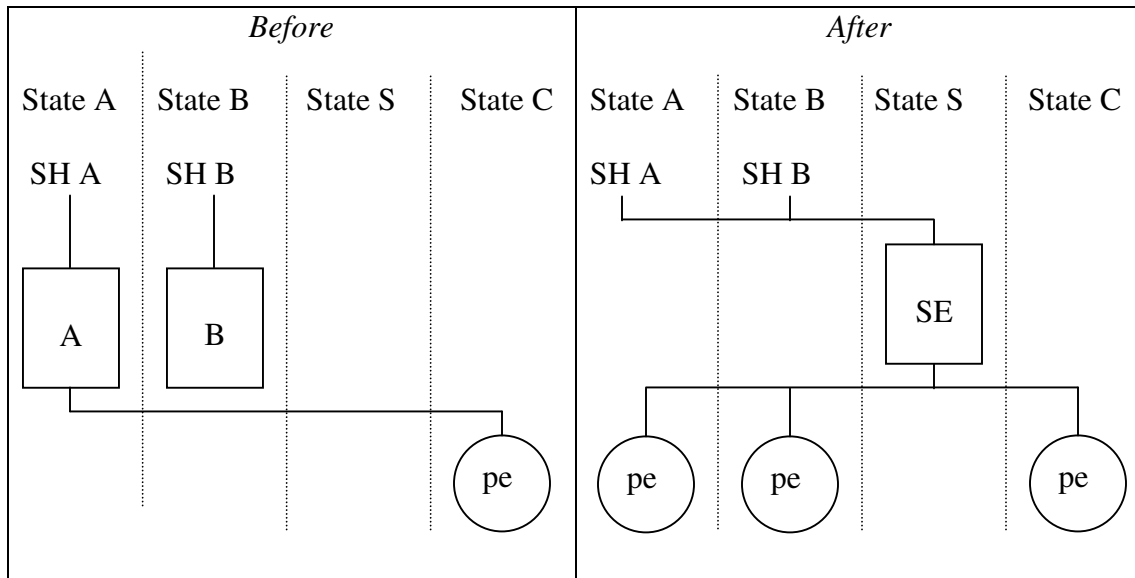

Facts and assumptions

- SH = shareholder(s), resident in the respective country in which SH is situated
- A and B are existing companies
- A has a permanent establishment in Member State C
- SE is a new company
- A and B are public limited-liability companies (see Annex I to Reg. 2157/2001)
- State A, State B, State C, and State S are EU Member States
- A:
 - formed under law of Member State A
 - registered office in Member State A
 - head office in Member State A
- B:
 - formed under law of Member State B
 - registered office in Member State B
 - head office in Member State B
- SE:
 - formed under law of Member State S
 - registered office in Member State S
 - head office in Member State S
 - will be covered by the EC Merger Directive

Transactions

- A:
 - transfers all assets and liabilities to SE
 - in exchange for shares of SE (and cash payment if any, not exceeding 10% of nominal value of shares to be issued) issued to shareholder(s) of A
 - will be wound up without going into liquidation
- B:
 - transfers all assets and liabilities to SE
 - in exchange for shares of SE (and cash payment if any, not exceeding 10% of nominal value of shares to be issued) issued to shareholder(s) of B
 - will be wound up without going into liquidation
- SE:
 - will be a newly formed SE
 - will be regarded as public limited-liability company governed by the law of Member State S

Questions

1. Assume Member State A is your country

First, the tax administration verifies if the restructuring operations falls within the scope of the definition provided in Art. 210-0-A-I of the General Tax Code (CGI). In this respect, the merger by formation of a new company falls within the scope of the definition.

Prior approval

The absorption of company A by company SE leads to the creation of a permanent establishment of SE in France. Since the asset transfer is made to a foreign company, prior approval is necessary to benefit from the favourable regime (see part 1.3.1 of the general introduction).

Upon approval, the receiving company must subscribe to the conditions of the favourable mergers regime as provided by Art. 210 A of the CGI. The permanent establishment of the receiving company will effectively abide by the restrictive conditions imposed by the tax authorities, for the account of the receiving company.

Tax effects for Company A in Member State A

1.a. Tax treatment of capital gains

Provided that company A is eligible to the favourable mergers regime, capital gains on mergers are exempt from corporate income tax. The French tax administration requires that the operation leads to the creation of a permanent establishment in France and verifies that all the assets and liabilities from the transferring companies are taken over

by the permanent establishment of the receiving company. For further details, see case 1 question 1.a.

1.b. Tax treatment of provisions and reserves

Reserves and provisions which do not lose their justification as a result of the merger need not be added back to the taxable income of company A. Instead, they are taken over by the French permanent establishment of SE.

1.c. Transfer of losses from the transferring to the receiving company

Transfer of losses available for carry-forward

The losses suffered by the transferring company prior to the merger, including losses corresponding to deferred depreciation, may only be transferred to the receiving company SE upon prior approval (CGI, Art. 209-II and Ann. IV, Art. 170 sexies). For the details on the approval, see part 1.3.2 of the general introduction.

Transfer of the loss carry-back receivable

The transfer of loss carry-back is possible in the event of a merger, qualifying or not to the preferential regime. Prior approval is not required.

1.d.e and f. Tax treatment of PE located abroad

Under the territoriality rule, gains and losses on the transfer to SE of the assets and liabilities of the foreign permanent establishment of a French company are generally ignored for French tax purposes.

Tax effects for SH A in Member State A

General rules

In a restructuring under the favourable regime, the allocation of shares by the receiving company SE is not treated as a distribution²⁰ and therefore does not trigger the imposition of the précompte (equalization tax) or income tax. If taxable on the gain, resident shareholders may qualify for roll-over relief (see below).

1.g. Tax treatment of the French-resident shareholders of the transferring company

i) SHA is a French-resident corporate shareholder

Resident corporate shareholder SH A may qualify for roll-over relief on gains realized upon the merger, and remain taxable in France upon disposal of the shares received in exchange if the tax treaty between France and the SE country attributes the taxation of gains on SE shares to France (as is often the case for gains on substantial participations under French treaties).

²⁰ Art. 115-1 of the CGI.

ii) SH A is a resident individual shareholder

SH A holding whether a substantial or non-substantial shareholding, is taxable on the gain only if his securities transaction volume during the relevant year exceeded EUR 15,000. If the transaction volume is so exceeded, SH A would still benefit, upon request, from roll-over relief. In that case, SA A remains taxable in France on gains on future disposal of the SE shares only if the tax treaty between France and the SE country attributes to the latter the right to tax gains on such disposal (which is often the case for gains on substantial participations under French treaties).

1.h. Tax treatment of non-resident shareholders

Tax treatment of foreign-resident individual shareholders

Non-resident individuals and corporate shareholders are generally not taxable on gains on French shares unless the shares are attributed to a French PE, or relate to French real estate, or to a substantial participation. Ordinarily, roll-over relief is available to such shareholders where the gain is taxable in France. In such case, however, future gains on the transfer of SE shares are taxable in France even if such gains would ordinarily not be taxable therein (because there is no link anymore between France and the shareholder).

2. Assume Member State S is your country

Tax effects for SE in Member State S

2.a. Value for tax purpose upon the merger

In case 2, the newly created SE absorbs three foreign companies. This restructuring operation leads to the formation of permanent establishments of SE in Member States A, B and C. Under to the French territoriality principle, these operations are neutral for tax purposes. The operation may be covered by the favourable mergers regime without prior approval from the tax administration. In this respect, SE must book the transferred assets at the book value they had in the transferring companies.

Some reporting requirements must be fulfilled. Under the French Commercial Code (C.com. art. L 233-15), all commercial companies having subsidiaries or branches must :

- draw a list of all subsidiaries and participations to be added to the financial statement;*
- provide the list of subsidiaries and participations in the annex to the accounts, which includes amongst other information, the share capital directly or indirectly held in the subsidiaries, the financial result of the subsidiaries, and the amount of share capital of the subsidiaries.*

Tax effects for shareholder(s) of SE in Member State

2.b. Consequences for SE's shareholders

Legal entities

The merger may have some tax consequences on the participation exemption regime²¹, when the participation in the transferring company becomes less than 5%. However, dividends received prior to the merger remain exempt, even though the shares were held for less than 2 years provided that the SE shareholders took the commitment to hold them for at least 2 years.

When the participation in the SE is less than 5%, the benefit of the long-term capital gains regime on substantial shareholding does not apply unless (i) the acquisition costs of the shares exceeded EUR 22.8 million (as from 1 January 2002), or (ii) the participation remains booked on a special account under "participation".

Individuals

There are no tax consequences for individual shareholders.

3. Assume Member State C is your country

Tax effects for A and SE in Member State C in respect of its permanent establishment in Member State C

3.a. Tax treatment of capital gains in Member State C

This restructuring operation leads to a change of ownership, which under French law has the consequences of a winding-up. To benefit from the roll-over relief provided by the favourable mergers regime, this operation requires prior approval from the French tax authorities. The latter is likely to be granted provided that the French assets be maintained on the balance-sheet of the foreign receiving company SE, and that transferring company A makes the commitment to hold the shares received in exchange for the transfer for a period of 3 years (see case 1, question 3.a).

3.b. Tax treatment of provisions and reserves

Reserves and provisions which remain justified are rolled-over at their book-value to the new PE.

3.c. Transfer of losses

²¹ Parent companies may opt for the participation exemption regime with respect to dividends received from a domestic or foreign subsidiary (Arts. 145 and 216 CGI). However, 5% of the qualifying dividends are deemed to correspond to the expenses incurred with respect to the participation and, thus, are subject to corporate tax. If the actual expenses incurred are less than 5%, only the lower amount corresponding to actual expenses is taxed. In order to qualify as a parent, the participation in the subsidiary must be 5% or more.

Survey on the Societas Europaea
September 2003

The losses suffered by PE A prior to the merger, including losses corresponding to deferred depreciation, may only be transferred to PE SE upon prior approval (CGI, Art. 209-II and Ann. IV, Art. 170 sexies). For further details, see case 1 (question 3.c.). Further, the transfer of loss carry-back is possible in the event of a merger, whether or not qualifying for the preferential regime. Prior approval is not required.

CASE 3

Formation of a Holding – SE – 1

(Art. 2 par. 2(a) jo. Art. 32, Art. 33 and Art. 34 Reg. 2157/2001)

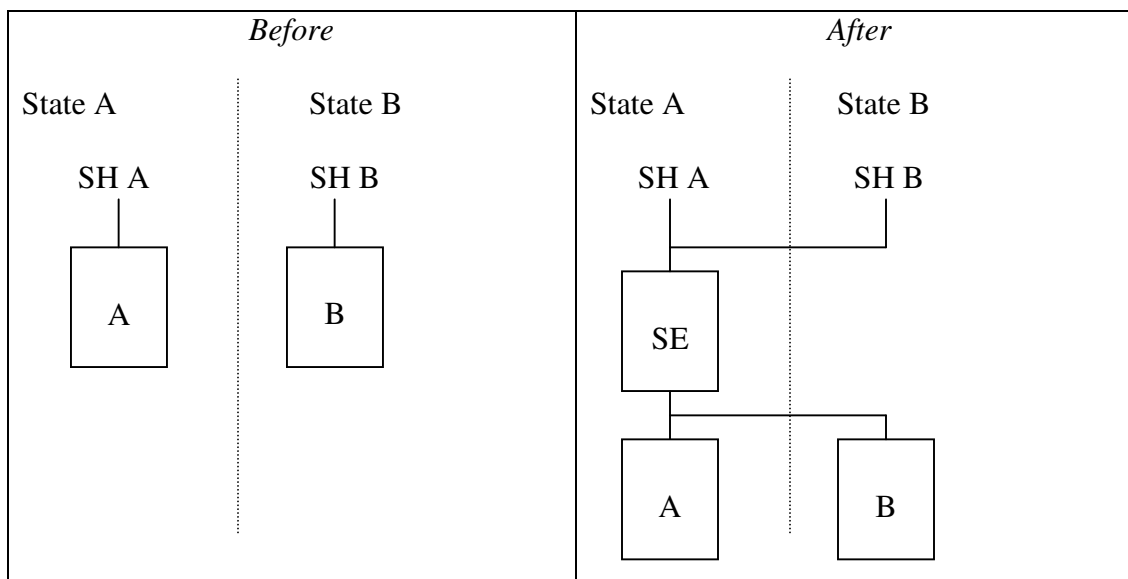

Facts and assumptions

- SH = shareholder(s), resident in the respective country in which SH is situated
- A and B are existing companies
- SE is a new company
- A and B are public or private limited-liability companies (see Annex II Reg. 2157/2001)
- State A and State B are EU Member States
- A:
 - formed under law of Member State A
 - registered office in Member State A
 - head office in Member State A
- B:
 - formed under law of Member State B
 - registered office in Member State B
 - head office in Member State B
- SE:
 - formed under law of Member State A
 - registered office in Member State A
 - head office in Member State A

- will be covered by the EC Merger Directive

Transactions

- SE:
 - will be regarded as public limited-liability company governed by the law of Member State A
 - acquires holding in A and B
 - such that it obtains more than 50% of the permanent voting rights in A and B
 - in exchange for shares in SE
 - issued to the shareholders of A and B

Questions

Introduction

An exchange of shares involves at least three parties: the transferring company (companies A and B), the receiving company (SE) and the shareholder(s) of the transferring company who, in exchange for shares from the transferring company, receive securities from the receiving company (SE).

Eligibility to the French preferential regime

Under French tax law and unlike the Mergers Directive, a partial transfer of assets also includes a qualifying exchange of shares. The French preferential mergers regime is applicable to such transaction. Since a partial transfer of assets relates to a specific assets or shareholding (i.e. 50% of the shareholding in case 3), the transferring company A continues to exist after the transaction, unlike transferring companies in a merger or division. The operation does not result in a liquidation or a dissolution of company A.

Contributions of shareholdings

Transfers of securities deemed to be equivalent to an autonomous branch of activities benefit from the preferential regime. French law has traditionally considered that the transfer of controlling shareholding is treated as a transfer of a branch of activity²². This is the case if the transfer relates to:

- *more than 50% of the capital of the company the shares of which are transferred;*
- *more than 30% of the voting rights following the transfer if no other shareholders hold a greater share of voting rights; or*
- *a shareholding equivalent to less than 30% of the voting rights prior to the transfer, but whose recipient obtains the greater part of the voting rights following the transfer.*

Indirect participations are excluded in the determination of the voting rights.

Exchange of shares may benefit from the preferential regime. Those involving the transfer of a participation to a foreign company require prior approval from the French

²² Guideline of 25 October 2002 (BOI 4-I-2-02)

*Ministry of Finance*²³. Prior approval may be granted provided that the conditions of Art. 210 B are met as follows:

- SH A (or SH B) must hold for at least 3 years the SE shares received in exchange for the transfer of company A shares, and commits to calculate future capital gains on the disposal of SE shares on the basis of the next book-value of company A (or B) shares before the exchange;
- Company SE must hold the shares in company A (or B) as long as SH A (or SH B) holds the shares in SE (i.e. at least 3 years);
- During the minimum 3-year holding period, SH A (or SH B) will have to address in the statement listing the deferred capital gains²⁴ the following items:
 - (i) the reference and the date of the prior approval's grant;
 - (ii) the identity of company A shareholders and the number of shares held by each of them; and
 - (iii) the value of the capital gains arising from the exchange of shares at the beginning and the end of the tax year.
- SH A (or SH B) will have to inform the French tax administration of any change affecting directly or indirectly the commitments pursuant to which the preferential regime was granted.

1. Assume Member State A is your country

Tax effects for SE in Member State A

1.a. Valuation of shares

Unlike in mergers operation, SE may book the shares received either (i) at the same book-value they had for shareholders SH A and SH B, or (ii) at their fair market value. In both cases, roll-over relief is granted subject to the conditions enacted in Art. 210 B (1) (see introduction).

1.b. Valuation of the issue of shares to SH A and B

Unlike in mergers operation, SH A and SH B may book the shares received either (i) at the same book-value they had for SE, or (ii) at their fair market value. In both cases, roll-over relief is granted subject to the conditions enacted in Art. 210 B (1) (see introduction).

Tax effects for SH A in Member State A

1.c. SH A and the acquired company are residents in France

The transfer would normally trigger the realization of capital gains or losses. For individual shareholders, who are not acting in the framework of a trade or business, such

²³ Art. 210 C(2) which refers to Art. 210 B.

²⁴ as provided in Art. 54 septies of the CGI.

gains are taxable but only if their annual transactions volume during the year exceeded EUR 15,000. Individual entrepreneurs benefit from the same roll-over relief as corporate shareholders. Nevertheless, they remain taxed at the same tax rate as individuals (i.e. 26% including social contributions).

The capital gains is determined depending on whether the SE shares were booked at their fair market value. Where the SE shares were booked at book value and the SE was already taxed in France on the disposal of the French shares received, the French-resident shareholder is allowed a step-up of the SE shares to fair market value and to compute the gains on the shares by reference to that value. This way, potential double taxation is avoided.

In both cases, however, the gain may benefit from roll-over relief.

The same applies to corporate shareholders.

1.d. Tax treatment of non-resident shareholders

Non-residents shareholders are not subject to tax on gains unless the gain is attributed to a French PE or relates to a substantial participation or French real estate. In this case, assuming the capital gain is taxable under French law and is not prevented by a tax treaty, roll-over relief is available if the conditions are satisfied.

The capital gains is determined depending on whether the SE shares were booked at their fair market value. Where the SE shares were booked at book value and the SE was already taxed in France on the disposal of the French shares received, the non-resident shareholder is allowed a step-up of the SE shares to fair market value and to compute the gains on the shares by reference to that value. This way, potential double taxation is avoided. Future gains on the SE shares may be exempt in France, for example if the participation in the SE is not substantial. Further details on the taxation on each type of shareholders, where the latter are taxable in France, are provided in case 1 answer 1.h.

2. Assume Member State B is your country

Tax effects for SH B in Member State B

2.a. Tax effect for resident shareholders

The exchange of shares is deemed to be a partial transfer of assets. Where the gain is taxable in France, roll-over relief is available to French resident shareholders subject to prior approval²⁵. The capital gains is determined depending on whether the SE shares were booked at their fair market value, and on whether the SE was already taxed in France on the same capital gains (where this is not prevented by a tax treaty). Where the SE shares were booked at book value and the SE was already taxed in France on the disposal of the French shares received, the French-resident shareholder is allowed a step-up of the SE shares to fair market value and to compute the gains on the shares by reference to that value. This way, potential double taxation is avoided..

²⁵ Prior approval is required under Art. 210 C-2, according to the conditions provided in Art. 210 B-3 of the CGI.

From another perspective, the exchange would also mean that French resident shareholders no longer enjoy the “avoir fiscal” imputation credit with respect to dividend distributions by B. Indeed, the “avoir fiscal” is only granted with respect to French-source dividends and the former B shareholders no longer receive a dividend directly from B but from a non-resident SE. Resident shareholders remain, however, eligible for the participation exemption on account of dividends received from the SE under the same conditions as for dividends previously received from company B. Further details on the taxation on each type of shareholders, where the latter are taxable in France, are provided in case 1 answer 1.g.

2.b. Tax effects for non-resident shareholders

Non-residents shareholders are not subject to tax on gains unless the gain is attributed to a French PE or relates to a substantial participation or French real estate. In this case, assuming the capital gain is taxable under French law and is not prevented by a tax treaty, roll-over relief is available if the conditions are satisfied. The capital gains is determined depending on whether the SE shares were booked at their fair market value, and on whether the SE was already taxed in France on the same capital gains (where this is not prevented by a tax treaty). Where the SE shares were booked at book value and the SE was already taxed in France on the disposal of the French shares received, the non-resident shareholder is allowed a step-up of the SE shares to fair market value and to compute the gains on the shares by reference to that value. This way, potential double taxation is avoided. Future gains on the SE shares may be exempt in France, for example if the participation in the SE is not substantial. Further details on the taxation on each type of shareholders, where the latter are taxable in France, are provided in case 1 answer 1.g.

Tax effect for SE in member state B

The French tax authorities will verify whether the SE keeps the shares received for at least 3 years (see conditions for prior approval). The tax authorities require the French company to notify them of any change of memberships and retain the right to reverse the roll-over in case of non-compliance with the holding period. Where the SE is taxable in France on capital gains on a future disposal of the French shares, and this taxation is not prevented by a tax treaty, the gain is determined by reference to the book value or the real market value, depending on the choice initially made by the two companies involved. Where the two companies had opted to use the book value method and the French company was already taxed on capital gains on the disposal of SE shares by reference to that value, the SE is entitled to a step-up to real market value in determining the gain on the French shares. This is to avoid potential double taxation.

CASE 4

Formation of a Holding – SE

(Art. 2 par. 2(a) and (b) jo. Art. 32, Art. 33, and Art. 34 Reg. 2157/2001)

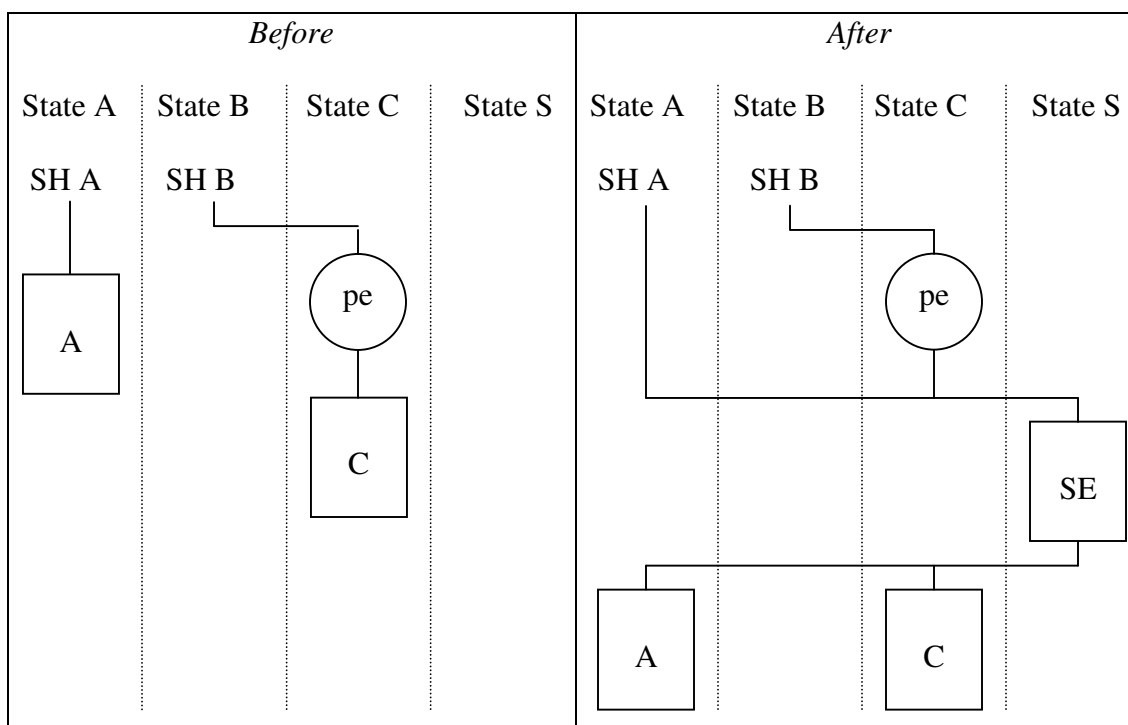

Facts and assumptions

- SH = shareholder(s), resident in the respective country in which SH is situated
- A and C are existing companies
- The shares in C are attributable to pe in State C
- SE is a new company
- A and C are public or private limited-liability companies (see Annex II)
- State A, State B, State C and State S are EU Member States
- A:
 - formed under law of Member State A
 - registered office in Member State A
 - head office in Member State A
- C:
 - formed under law of Member State C
 - registered office in Member State C
 - head office in Member State C
- SE:

- formed under law of Member State S
- registered office in Member State S
- head office in Member State S
- will be covered by the EC Merger Directive

Transactions

- SE:
 - will be regarded as public limited-liability company governed by the law of Member State S
 - acquires holding in A and C
 - such that it obtains more than 50% of the permanent voting rights in A and C
 - in exchange for shares in SE
 - issued to the shareholders of A and C

Questions

Introduction

Operations of exchange of shares may benefit from the preferential regime. Those involving a participation transfer to a foreign company must receive a prior approval from the French Ministry of Finance²⁶. Prior approval may be granted provide that the conditions of Art. 210 B are met as follow:

- *SH A (or SH B) must hold for at least 3 years the SE shares received in exchange for the transfer of company A shares, and commits to calculate future capital gains on the disposal of SE shares on the basis of the next book-value of company A shares before the exchange;*
- *Company SE must hold the shares in company A as long as SH A (or SH B) holds the shares in SE (i.e. at least 3 years)*
- *During the 3 years holding period, SH A (or SH B) will have to address in the statement listing the deferred capital gains²⁷ the following items:*
 - *(i) the reference and the date of the prior approval's grant,*
 - *(ii) the identity of company A shareholders and the number of shares held by each of them, and*
 - *(iii) the value of the capital gains arising from the exchange of shares at the beginning and the end of the tax year.*
- *SH A (or SH B) will have to inform the French tax administration of any change affecting directly or indirectly its commitments under which the preferential regime has been granted.*

1) Assume Member State A is your country

²⁶ Art. 210 C(2) which refers to Art. 210 B.

²⁷ as provided in Art. 54 septies of the CGI.

Tax effects for SH A in Member State A

1.a. SH A is a French resident

The transfer of controlling shareholding is treated as a partial transfer of assets under French tax law. Since the transfer is made to a non-resident SE, prior approval of the Ministry of Finance is required. If approval is granted, roll-over relief is available to French-resident shareholders. The French-resident shareholder may book the shares received either at their fair market value or at the book value of the shares contributed. In both cases, roll-over relief is granted subject to the conditions enacted in Art. 210 B (1) (see introduction). On a future sale of the SE shares, the capital gains is determined depending on whether the SE shares were booked at their fair market value, and on whether the SE was already taxed in France on the same capital gains (where this is not prevented by a tax treaty). Where the SE shares were booked at book value and the SE was already taxed in France on the disposal of the French shares received, the French-resident shareholder is allowed a step-up of the SE shares to fair market value and to compute the gains on the shares by reference to that value. This way, potential double taxation is avoided. Further details on the taxation on each type of shareholders, where the latter are taxable in France, are provided in case 1 answer 1.g.

1.b. Tax effects for non-resident shareholders

Non-residents shareholders are not subject to tax on gains unless the gain is attributed to a French PE or relates to a substantial participation or French real estate. In this case, assuming the capital gain is taxable under French law and is not prevented by a tax treaty, roll-over relief is available if the conditions are satisfied. The non-resident shareholder may book the shares received either at their fair market value or at the book value of the shares contributed. In both cases, roll-over relief is granted subject to the conditions enacted in Art. 210 B (1) (see introduction). On a future sale of the SE shares, the capital gains is determined depending on whether the SE shares were booked at their fair market value, and on whether the SE was already taxed in France on the same capital gains (where this is not prevented by a tax treaty). Where the SE shares were booked at book value and the SE was already taxed in France on the disposal of the French shares received, the non-resident shareholder is allowed a step-up of the SE shares to fair market value and to compute the gains on the shares by reference to that value. This way, potential double taxation is avoided. Future gains on the SE shares may be exempt in France, for example if the participation in the SE is not substantial. Further details on the taxation on each type of shareholders, where the latter are taxable in France, are provided in case 1 answer 1.h.

1.c. Tax effect for SE

The French tax authorities will verify whether the SE keeps the shares received for at least 3 years (see conditions for prior approval). The tax authorities require the French company to notify them of any change of memberships and retain the right to reverse the roll-over in case of non-compliance with the holding period. Where the SE is taxable in

France on capital gains on a future disposal of the French shares, and this taxation is not prevented by a tax treaty, the gain is determined by reference to the book value or the real market value, depending on the choice initially made by the two companies involved. Where the two companies had opted to use the book value method and the French company was already taxed on capital gains on the disposal of SE shares by reference to that value, the SE is entitled to a step-up to real market value in determining the gain on the French shares. This is to avoid potential double taxation.

2) Assume Member State B is your country

Tax effects for SH B in Member State B

SHB is a French-resident shareholder

Under the territoriality rules of French income tax, gains on the disposal of shares held through a foreign permanent establishment are not taxable in France.

3) Assume Member State C is your country

Tax effects for SH B in Member State C

3.a. Issue of shares to p.e. of SH B

Under the restructuring operation, the permanent establishment of SH B in France receives SE shares in exchange for the participation in company C. The permanent establishment is liable to tax in France on gains on the transaction unless it receives prior approval from the tax administration. If prior approval is granted, PE of SH B may book the shares received either at their fair market value or at the book value of the shares contributed. In both cases, roll-over relief is granted subject to the conditions enacted in Art. 210 B (1) (see introduction). On a future sale of the SE shares, the capital gains is determined depending on whether the SE shares were booked at their fair market value, and on whether the SE was already taxed in France on the same capital gains (where this is not prevented by a tax treaty). Where the SE shares were booked at book value and the SE was already taxed in France on the disposal of the French shares received in company C, the French-resident shareholder is allowed a step-up of the SE shares to fair market value and to compute the gains on the shares by reference to that value. This way, potential double taxation is avoided.

4) Assume Member State S is your country

Tax effects for SE in Member State S

a) Valuation for tax purpose of the shares received

Following the transaction, an SE resident in France becomes a shareholder in two non-resident companies. The SE itself being held by company A and company B (through a p.e. in C). The SE may book the A and C shares received either at their fair market value

or at the book value of the shares contributed. In both cases, roll-over relief is granted subject to the conditions enacted in Art. 210 B (1) (see introduction). On a future sale of the contributed shares, the capital gains is determined depending on whether the A and C shares were booked at their fair market value, and on whether SH A and SH B were already taxed in France on the same capital gains (where this is not prevented by a tax treaty). Where the A and C shares were booked at book value and SH A and SH B were already taxed in France on the disposal of the French shares received in SE, the French-resident shareholder is allowed a step-up of A and C shares to fair market value and to compute the gains on the shares by reference to that value. This way, potential double taxation is avoided

b) Valuation for tax purpose of SE shares issued to SH A and SH B

Under the preferential regime, the shares received in exchange for the transfer must be held by SH A and PE of SH B in Member State C for 3 years. SH A and SH B may be liable to tax on a future disposal of SE shares if the shares represent a substantial participation or are related to French real estate and such taxation is not prevented by a tax treaty. Where taxable in France, gains on the disposal of SE shares would have to be determined depending on whether the shares were booked at fair market value, or at book value (where SE may be allowed a step up under certain conditions).

CASE 5

Formation of a Holding – SE

(Art. 2 par. 2(b) jo. Art. 32, Art. 33, and Art. 34 Reg. 2157/2001)

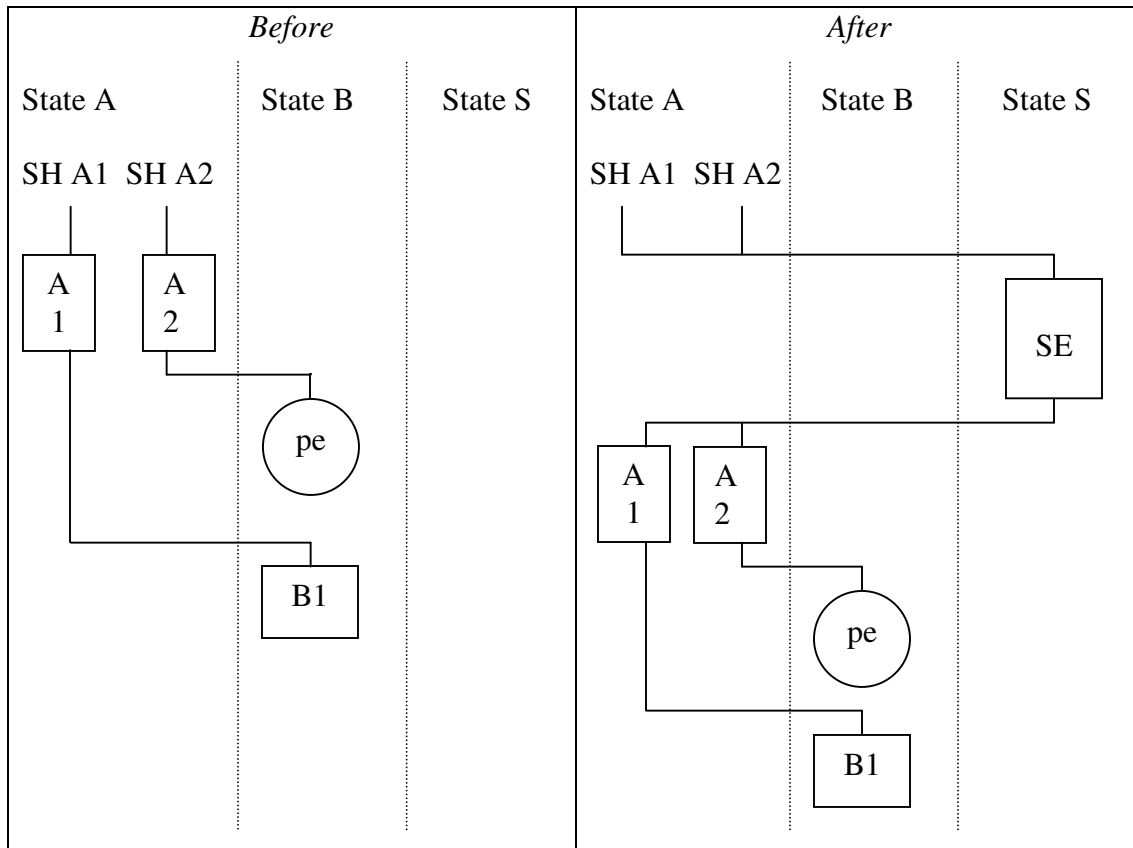

Facts and assumptions

- SH = shareholder(s), resident in the respective country in which SH is situated
- A1, A2, and B1 are existing companies
- pe is an existing permanent establishment of A2 in Member State B
- SE is a new company
- A1, A2, and B1 are public or private limited-liability companies (see Annex II to Reg. 2157/2001)
- State A, State B, and State S are EU Member States
- A1 and A2:
 - formed under law of Member State A
 - registered office in Member State A
 - head office in Member State A
- B1:
 - formed under law of Member State B
 - registered office in Member State B

- head office in Member State B
- SE:
 - formed under law of Member State S
 - registered office in Member State S
 - head office in Member State S
 - will be covered by the EC Merger Directive

Transactions

- SE:
 - will be regarded as public limited-liability company governed by the law of Member State S
 - acquires holding in A1 and A2
 - such that it obtains more than 50% of the permanent voting rights in A1 and A2
 - in exchange for shares in SE
 - issued to the shareholders of A1 and A2

Questions

1) Assume Member State A is your country

Tax effects for SH A2 in Member State A

1.a. Issue of SE shares to SH A2

The transfer of controlling shareholding is treated as a partial transfer of assets under French tax law. Since the transfer is made to a non-resident SE, prior approval of the Ministry of Finance is required. If approval is granted, roll-over relief is available to French-resident shareholders. The French-resident shareholder may book the shares received either at their fair market value or at the book value of the shares contributed. In both cases, roll-over relief is granted subject to the conditions enacted in Art. 210 B (1) (see introduction). On a future sale of the SE shares, the capital gains is determined depending on whether the SE shares were booked at their fair market value, and on whether the SE was already taxed in France on the same capital gains (where this is not prevented by a tax treaty). Where the SE shares were booked at book value and the SE was already taxed in France on the disposal of the French shares received, the French-resident shareholder is allowed a step-up of the SE shares to fair market value and to compute the gains on the shares by reference to that value. This way, potential double taxation is avoided. Further details on the taxation on each type of shareholders, where the latter are taxable in France, are provided in case 1 answer 1.g.

It should be noted that the exchange would also mean that French resident shareholder A1 no longer enjoy the “avoir fiscal” imputation credit with respect to dividend distributions by A1. Indeed, the “avoir fiscal” is only granted with respect to French-source dividends and the former A1 shareholders no longer receive a dividend directly

from A1 but from a non-resident SE. Resident shareholders remain, however, eligible for the participation exemption on account of dividends received from the SE under the same conditions as for dividends previously received from company A1.

2) Assume Member State S is your country

Tax effects for SE in Member State S

2.a. *Valuation for tax purposes of the shares of A1 and A2 acquired by SE*

Following the transaction, an SE resident in France becomes a shareholder in two non-resident companies. The SE itself being held by SH A1 and SH A2. The SE may book the A1 and A2 shares received either at their fair market value or at the book value of the shares contributed. In both cases, roll-over relief is granted subject to the conditions enacted in Art. 210 B (1) (see introduction). On a future sale of the contributed shares, the capital gains is determined depending on whether the A1 and A2 shares were booked at their fair market value, and on whether SH A1 and SH A2 were already taxed in France on the same capital gains (where this is not prevented by a tax treaty). Where the A1 and A2 shares were booked at book value and SH A1 and SH A2 were already taxed in France on the disposal of the French shares received in SE, the French-resident shareholder is allowed a step-up of A1 and A2 shares to fair market value and to compute the gains on the shares by reference to that value. This way, potential double taxation is avoided

Special regime for listed companies:

When the receiving and the transferring companies are listed on a stock exchange, another regime may apply: the regime of the “exchange public offer”(offre publique d’échange). For this regime, the fiscal value of the shares corresponds to the real value at the date of the exchange.

2.b. *Valuation of SE shares*

Under the preferential regime, the shares received in exchange for the transfer must be held by SH A1 and SH A2 in France for 3 years. SH A1 and SH A2 may be liable to tax on a future disposal of SE shares if the shares represent a substantial participation or are related to French real estate and such taxation is not prevented by a tax treaty. Where taxable in France, gains on the disposal of SE shares would have to be determined depending on whether the shares were booked at fair market value , or at book value (where SE may be allowed a step up under certain conditions).

CASE 6

Formation of a Subsidiary–SE by exchange of shares (Art. 2 par. 3(a) jo. Arts. 35 and 36 Reg. 2157/2001)

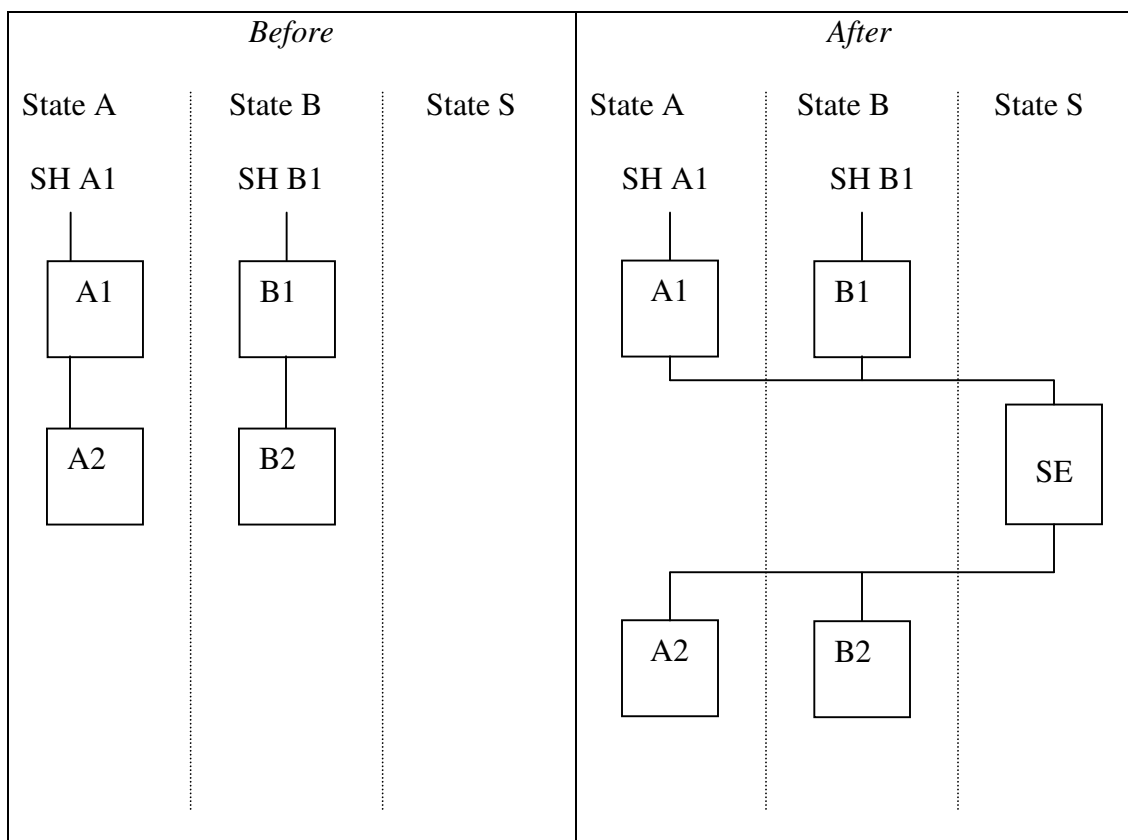

Facts and assumptions

- SH = shareholder(s), resident in the respective country in which SH is situated
- A1, A2, B1, and B2 are existing companies
- SE is a new company
- A1 and B1 are companies or firms within the meaning of Art. 48 par. 2 of the Treaty establishing the European Community or other legal bodies governed by public or private law (Art. 2 par. 3 Reg. 2157/2001)
- State A, State B, and State S are EU Member States
- A1 and A2:
 - formed under law of Member State A
 - registered office in Member State A
 - head office in Member State A
- B1 and B2:
 - formed under law of Member State B

- registered office in Member State B
- head office in Member State B

- SE:
 - formed under law of Member State S
 - registered office in Member State S
 - head office in Member State S
 - will be covered by the EC Merger Directive

Transactions

- A1 and B1:
 - *form a subsidiary SE by way of contributing their subsidiaries A2 and B2 respectively to SE*
- SE:
 - will be regarded a public limited-liability company governed by the law of Member State S
 - will acquire the shares in A2 and B2 in exchange for shares issued to A1 and B1

Questions

- 1) Assume Member State A is your country

Introduction

Tax effects for A1 in Member State A

- a) *Tax treatment of capital gains arising from the exchange of shares*

The transaction implies that A1 exchanges a controlling shareholding in A2 against shares in a non-resident company. The transfer of controlling shareholding is treated as a partial transfer of assets under French tax law. Since the transfer is made to a non-resident SE, prior approval of the Ministry of Finance is required. If approval is granted, roll-over relief is available to French-resident shareholders. Company A1 may book the shares received either at their fair market value or at the book value of the shares contributed. In both cases, roll-over relief is granted subject to the conditions enacted in Art. 210 B (1) (see introduction). On a future sale of the SE shares, the capital gains is determined depending on whether the SE shares were booked at their fair market value, and on whether the SE was already taxed in France on the same capital gains (where this is not prevented by a tax treaty). Where the SE shares were booked at book value and the SE was already taxed in France on the disposal of the French shares received, the French-resident shareholder is allowed a step-up of the SE shares to fair market value and to compute the gains on the shares by reference to that value. This way, potential

double taxation is avoided. Further details on the taxation on each type of shareholders, where the latter are liable to taxable in France, are provided in case 1 answer 1.g.

It should be noted that the exchange would also mean that French resident shareholder A1 no longer enjoy the “avoir fiscal” imputation credit with respect to dividend distributions by A1. Indeed, the “avoir fiscal” is only granted with respect to French-source dividends and the former A1 shareholders no longer receive a dividend directly from A1 but from a non-resident SE. Resident shareholders remain, however, eligible for the participation exemption on account of dividends received from the SE under the same conditions as for dividends previously received from company A1.

Tax effects for SH A1

SH A1 is not directly affected by the exchange of shares. Nevertheless, A1 may redistribute the SE shares received in the framework of the exchange to shareholder SH A1. The allocation can be made tax-free to shareholder SH A1 if operated within one year from the exchange. As this condition automatically conflicts with the requirement for A1 to hold SE shares for at least 3 years in order to benefit from roll-over relief, a prior approval from the tax authorities is needed.

2) Assume Member State S is your country

Tax effects for SE in Member State S

2.a. Valuation of shares in A2 and B2

Following the transaction, an SE resident in France becomes a shareholder in two non-resident companies. The SE itself being held by company A1 and company B1. The SE may book the A2 and B2 shares received either at their fair market value or at the book value of the shares contributed. In both cases, roll-over relief is granted subject to the conditions enacted in Art. 210 B (1) (see introduction). On a future sale of the contributed shares, the capital gains is determined depending on whether the A2 and B2 shares were booked at their fair market value, and on whether A1 and B1 were already taxed in France on the same capital gains (where this is not prevented by a tax treaty). Where the A1 and B2 shares were booked at book value and A1 and B1 were already taxed in France on the disposal of the French shares received in SE, SE is allowed a step-up of A2 and B2 shares to fair market value and to compute the gains on the shares by reference to that value. This way, potential double taxation is avoided

2.b. Valuation for tax purpose of SE shares issued to A1 and B1

Under the preferential regime, the shares received in exchange for the transfer must be held by A1 and B1 in France for at least 3 years. A1 and B1 may be liable to tax on a future disposal of SE shares if the shares represent a substantial participation or are related to French real estate and such taxation is not prevented by a tax treaty. Where taxable in France, gains on the disposal of SE shares would have to be determined

Survey on the Societas Europaea
September 2003

*depending on whether the shares were booked at fair market value , or at book value
(where SE may be allowed a step up under certain conditions).*

CASE 7

Formation of a Subsidiary–SE by contribution of cash (Art. 2 par. 3(a) jo. Arts. 35 and 36 Reg. 2157/2001)

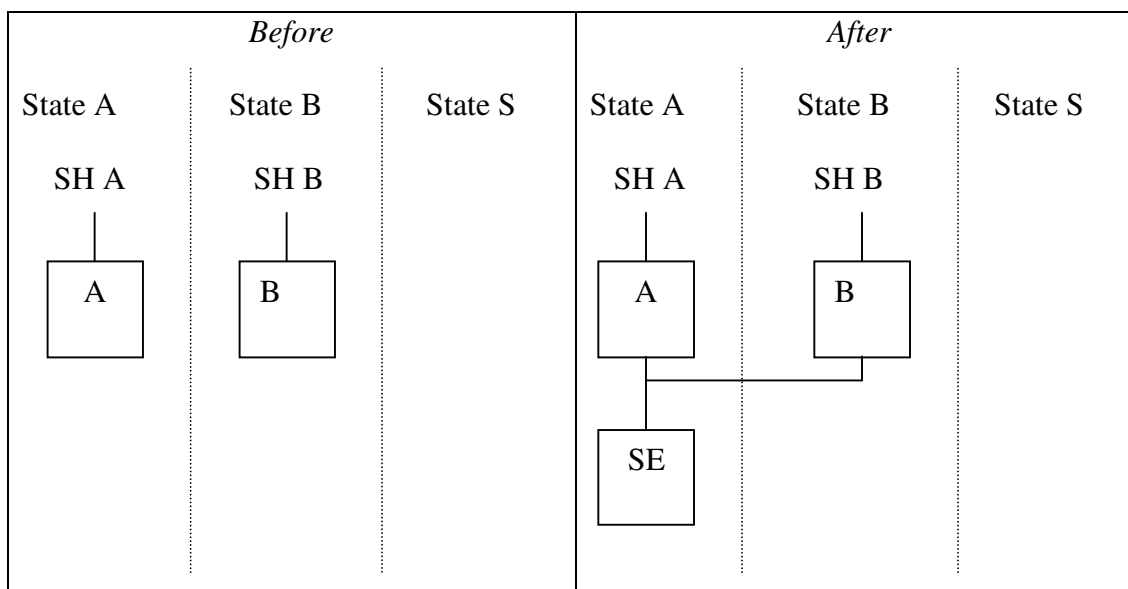

Facts and assumptions

- SH = shareholder(s), resident in the respective country in which SH is situated
- A, and B are existing companies
- SE is a new company
- A and B are companies or firms within the meaning of Art. 48 par. 2 of the Treaty establishing the European Community or other legal bodies governed by public or private law (Art. 2 par. 3 Reg. 2157/2001)
- State A, State B, and State S are EU Member States
- A:
 - formed under law of Member State A
 - registered office in Member State A
 - head office in Member State A
- B:
 - formed under law of Member State B
 - registered office in Member State B
 - head office in Member State B
- SE:
 - formed under law of Member State A
 - registered office in Member State A
 - head office in Member State A
 - will be covered by the EC Merger Directive

Transactions

- *SE*:
 - will take the form of an SE
 - will be regarded a public limited-liability company governed by the law of Member State A
- A and B:
 - *form a subsidiary SE*

Questions

1) Assume Member State A is your country

Tax effects for A in Member State A

1.a. Tax effects of the formation of the subsidiary SE in Member State A

There are no direct tax consequences in Member State A upon the formation of the subsidiary SE. The formation of the subsidiary SE will entail some registration duties.

2) Assume Member State B is your country

Tax effects for B in Member State B

Will there be any tax effect for B in Member State B as a consequence of the formation of the subsidiary SE in Member State A?

No.

CASE 8

Formation of a Subsidiary–SE by transfer of assets

(Art. 2 par. 3(a) jo. Arts. 35 and 36 Reg. 2157/2001)

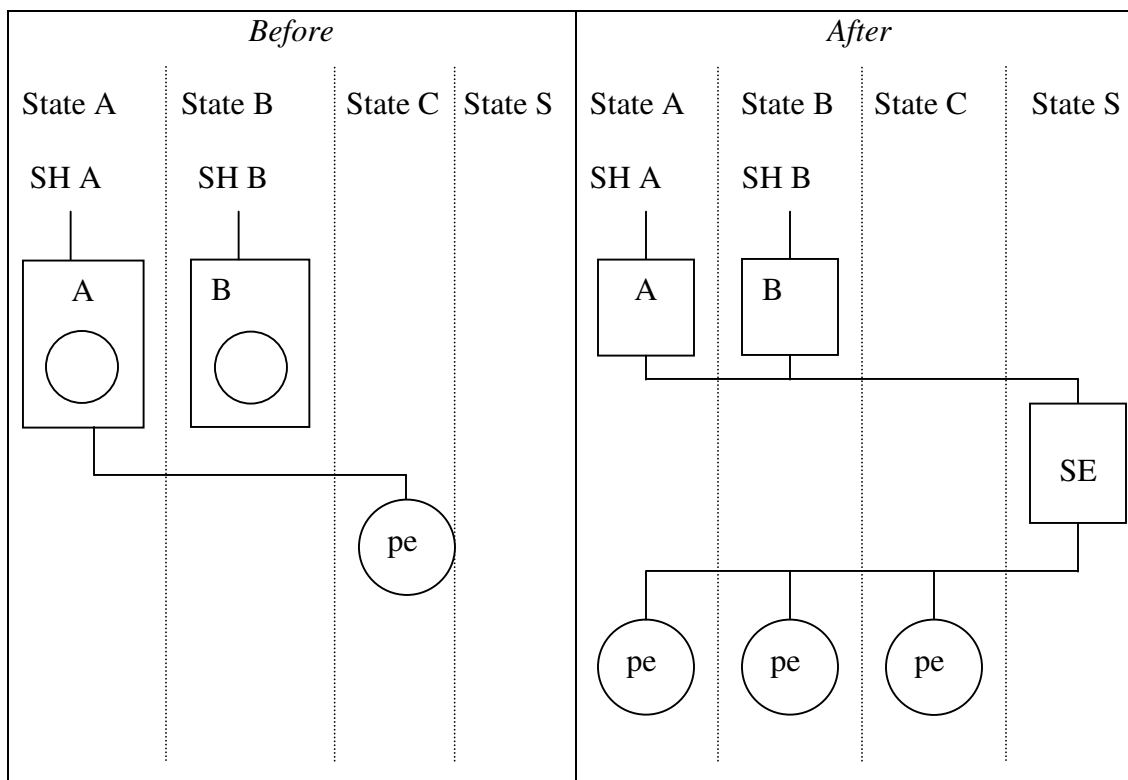

Facts and assumptions

- SH = shareholder(s), resident in the respective country in which SH is situated
- A, and B are existing companies
- SE is a new company
- A and B are public or private limited-liability companies (see Annex II)
- A and B are companies or firms within the meaning of Art. 48 par. 2 of the Treaty establishing the European Community or other legal bodies governed by public or private law
- A has a permanent establishment in State C
- State A, State B, State C and State S are EU Member States
- A:
 - formed under law of Member State A
 - registered office in Member State A
 - head office in Member State A
- B:
 - formed under law of Member State B
 - registered office in Member State B

- head office in Member State B
- SE:
 - formed under law of Member State S
 - registered office in Member State S
 - head office in Member State S
 - will be covered by the EC Merger Directive

Transactions

- SE:
 - will take the form of an SE
 - will be regarded a public limited-liability company governed by the law of Member State S
- A (and B):
 - *form a subsidiary by way of contributing their branches in Member State A (and B respectively) to SE in exchange for the issue of shares by SE to A (and B respectively)*
- A:
 - will transfer its permanent establishment in Member State C to SE in exchange for the issue of shares by SE to A

Questions

1) Assume Member State A is your country

Tax effects for A and SE in Member State A

1.a. Tax treatment of capital gains upon the transfer of assets

The transfer of a branch of activity by a French company to an SE located in a Member State S leads to the creation in France of a permanent establishment of the foreign receiving company. Transfers from a French company to a foreign one must receive a prior approval from the French tax authorities to benefit from the preferential regime. If the capital gains on the disposal of the assets may be taxed in France, the prior approval will be easily granted. The latter will provide for the usual conditions with regard to the 3 years shareholding requirement and the computation of future capital gains based on the net book value of the assets before the transfer.

1.b. Accounting value of the shares

The shares received must be booked at the net-book value of the assets of the transferring company.

1.c. Transfer of losses from A to PE SE in Member State A

Transfer of losses available for carry-forward

The losses suffered by A prior to the merger may only be transferred to PE SE upon prior approval (CGI, Art. 209-II and Ann. IV, Art. 170 sexies).

1d. Taxation of PE C in member State A

Under the territoriality rule (see General introduction), assets connected with a permanent establishment located in Member State C are generally ignored for French tax purposes. Therefore, capital gains realized at the time of the transfer of assets of A's permanent establishment to Company SE are exempt in France. By the same token, losses incurred by the foreign establishment may not be deducted from the taxable income of the transferring French company.

2) Assume Member State S is your country

Tax effects for SE in Member State S

- a) Attribution of the value for tax purpose of PEs in Member State A,B and C

According the French territoriality rules, permanent establishments located abroad are ignored for French tax purposes.

Tax effects for A as shareholder of SE in Member State S

- b) Is there any provision in the tax legislation of Member State S that affects A as shareholder of SE?

Non-resident corporate shareholders (company A) are generally not taxable on gains on French shares unless the shares are attributed to a French PE, or relate to French real estate, or to a substantial participation. Ordinarily, roll-over relief is available to such shareholders where the gain is taxable in France.

3) Assume Member State C is your country

Tax effects for A and SE in Member State C in respect of its permanent establishment in Member State C

3.a. Taxation of capital gains of PE A in Member state C

The asset transfer results in the change of ownership of the French permanent establishment from Company A to company SE, both located abroad, which leads to a liquidation. Nevertheless, the tax authorities accepts that the favourable mergers regime applies provided that the receiving company SE takes in the mergers agreement the commitment to respect the requirements provided in Art. 210 A (See case 1, answer 1.a.). In practice, the situation of the permanent establishment will remain unchanged if the net book value of the assets remains unchanged.

3.b. Tax treatment of provisions and reserves

Reserves and provisions which remain justified need not be taxed upon the merger but may be taken over in the books of PE SE.

3.c. Transfer of losses from PE A to PE SE

The losses suffered by PE A prior to the merger, including losses corresponding to deferred depreciation, may only be transferred to PE SE upon prior approval (CGI, Art. 209-II and Ann. IV, Art. 170 sexies)²⁸.

²⁸ For further details on the transfer of losses, see Guideline of 21 August 2002 (BOI 13-D-2-02) .

CASE 9

Transformation of public limited-liability company into an SE

(Art. 2 par. 4 jo. Art. 37 Reg. 2157/2001)

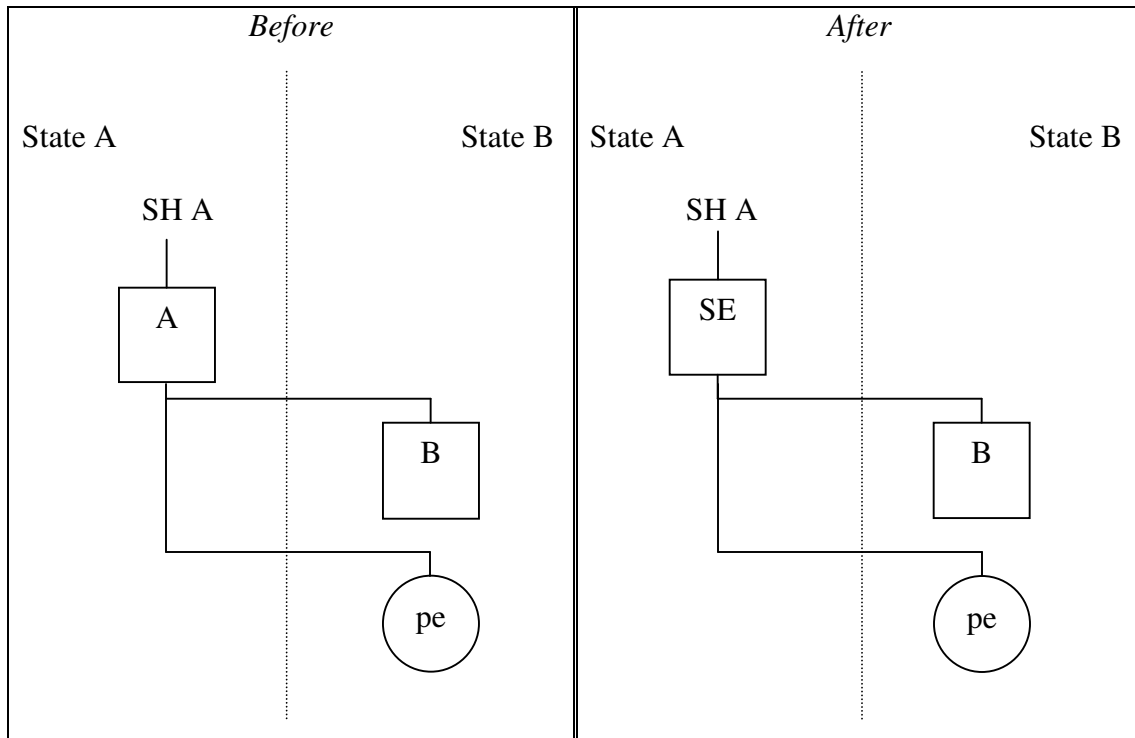

Facts and assumptions

- SH = shareholder(s), resident in the respective country in which SH is situated
- A and B are existing companies
- pe is an existing permanent establishment
- A and B public limited-liability companies (see Annex I of Reg. 2157/2001)
- State A and State B are EU Member States
- A:
 - formed under law of Member State A
 - registered office in Member State A
 - head office in Member State A
- B:
 - formed under law of Member State B
 - registered office in Member State B
 - head office in Member State B

Transactions

- A will be transformed into an SE, governed by the law of Member State A (Pursuant to Art. 37 par. 2 Reg., the transformation shall not result in the winding up of A or in the creation of a new legal person. However, the Regulation itself does not give guidance with regard to taxation.)

As a general rule, the transformation of a company into another legal form may lead to the creation of a new legal entity. In this respect, the operation leads to the tax consequence of a liquidation²⁹. Nevertheless, under certain conditions, the transformation of a public-limited liability company into an SE does not lead to the creation of a new legal entity, since the fiscal regime of corporate income tax continues to apply.

1) France is Member State A

Tax effects for A in Member State A

a) Tax consequence in France of the change of legal form from A to SE

Company law aspects

Under the Regulation of 8 October 2001³⁰, SA and SARL may be transformed into an SE if for at least two years it has had a subsidiary company governed by the law of another State.

Article 1844-3 of the Civil Code stipulates that the regular transformation of a company into another legal form does not lead to the creation of a new legal entity. The company keeps its assets and liabilities, as under the previous legal form.

Under French Company law, a company may change its legal form provided that all the legal requirements of the new legal form are met (number of shareholders, minimum capital requirement, nomination of statutory auditors. For this purpose, a French stock company (SA or SARL) may have to increase their subscribed share capital to the minimum requirement of EUR 120,000. According to Art. 225 to 243 of the French Commercial Code, an SA may change its legal form provided that it had existed for more than two years and that the last two annual statements have been approved by the shareholders. The transformation of the SA into an SE will probably have to be approved by the shareholders, at a quorum to be determined by law.

Tax law aspects

Direct tax

²⁹ Art. 201 of the CGI

³⁰ Council Regulation (EC) No 2157/2001 of 8 October 2001 on the statute for a European company (SE).

The transformation of a company into another form is treated as a liquidation for corporate tax purposes only if it implies a change of the applicable tax regime (e.g. a change from liability to corporate tax to transparent treatment as a partnerships). Since the SE will in all likelihood be treated in France as a corporate tax entity, the transformation of company A into an SE will not be treated as a liquidation. In this case, the transformation will be tax neutral for company A.

Note that a transformation of a company into another corporate form is treated as a cessation of business, implying substantially the same consequences as a liquidation, if the transformation is accompanied by a profound change of activities and not so much a change of the statutory purpose of the company.

The liquidation of the company implies the immediate taxation of profits and (hidden) reserves, the expiry of any previously available tax deferral, and the expiry of loss-carry forwards (although the losses can still be set-off against income of the year of liquidation).

Registration duties

The regular transformation of A into another form (SE) should be tax neutral for registration tax purposes (a fee equal to EUR 75 is, however, due). French case law, including that of the supreme Civil Court, has traditionally considered that the regular transformation of a company into another corporate form does not entail the imposition of registration duties even if the transformation is accompanied by important changes of activity or of statutory purpose. Nevertheless, the French tax authorities maintain that registration duties may become payable where the regular transformation is accompanied by important changes of the actual activities or the statutory purpose.

b) Transfer of losses

Since the change of legal form is not accompanied by a change of activities/statutory purpose (see above), assets and liabilities remain unchanged on the balance-sheet of newly created SE. As a consequence, losses of company A are taken into account for the computation of tax liability of company SE.

Tax effects for SH A in Member State A

c) Consequences of the transformation for SH A

The rights of the shareholders remain unchanged with respect to the transformation of a public limited-liability company into an SE. Upon the change of a French stock company into another French stock company³¹, there are in principle no tax consequences for the shareholders of the company. The shareholding level may decrease while the share capital of the new SE is increased to meet the new legal requirement. If the shareholding level decrease to a level of less than 5%, SH A will not benefit from the participation exemption regime anymore.

³¹ According to Art. 1 of the Council Regulation (EC) No 2157/2001 of 8 October 2001, the SE is a stock company, liable to corporate income tax.

2) Assume Member State B is your country

Tax effects for the shareholder of B in Member State B

The transaction implies that B which was held by A is now held by SE subsequent to a transformation of A into SE. Equally, the PE of A is now a PE of SE as a result of the same transaction.

There are no express rules under French tax law dealing with this situation. According to informal information from the French Ministry of Finance, a change of ownership of a French company or permanent establishment as a result of a transformation of a non-resident legal entity into another legal entity would be treated similarly to a domestic situation.

Therefore, if the transformation is regular and does not entail a change of the tax regime, it would have no direct tax consequences in France.

CASE 10

Transfer of registered office of an SE

(Art. 8 par. 1 jo. Art. 37 Reg. 2157/2001)

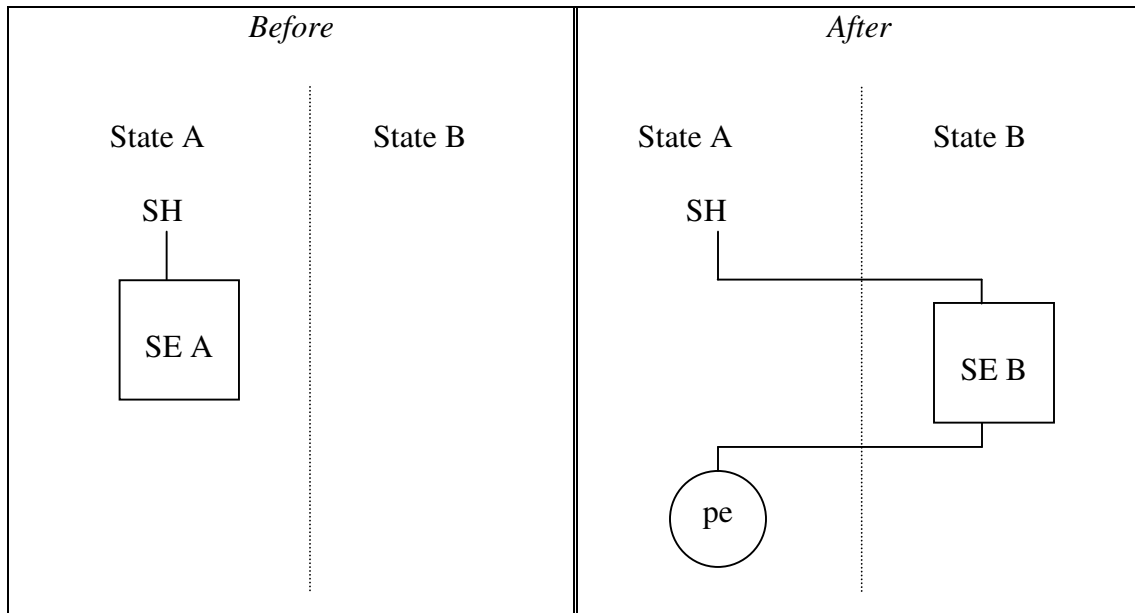

Facts and assumptions

- SE is an existing SE
- State A and State B are EU Member States
- SE A:
 - formed under the law of Member State A
 - registered office in Member State A
 - head office in Member State A
- SE B:
 - statutes are amended to conform to the law of Member State B
 - registered office in Member State B
 - head office in Member State B

Transactions

- registered office and head office of SE are transferred to Member State B (pursuant to Art. 8 Reg. 2157/2001 such a transfer shall not result in the winding up of SE or in the creation of a new legal person)

Questions

- 1) Assume Member State A is your country

a) *Consequences of the transfer*

Company law aspects

The Law of 1966 provides that any company which has its registered office in French territory is subject to French law. Case law requires that the location of a company's registered office should be genuine. The rule has therefore been developed that a registered office can be deemed to exist when it is the only place where board meetings and shareholders' meetings are convened, and most of the other management bodies (general, legal and financial management) are separately located. A company can only transfer its registered office with the express authorization of the bodies empowered to modify the articles of association. The registered office is in fact one of the main items defined in the articles of association.

Tax law aspects

The transfer abroad of a registered office previously located in France leads under French tax law to the winding-up of the company. With regard to stock companies, French law³² provides that a company may change its nationality, provided the new country of residence has concluded a favourable treaty with France enabling acquisition of nationality and the transfer of the registered office to its territory with maintenance of the company's legal personality. For tax purposes, when the above conditions are fulfilled, the imposition of tax is suspended insofar as the company has not been dissolved.

These provisions are currently not in effect as no such treaties have been concluded by France.

Tax effects of the transfer for SE

b) Tax consequences in case of a winding up of SE

If a company is liquidated, all income not yet taxed becomes immediately taxable. The normal corporate income tax rules generally apply, but all untaxed income is added back to taxable income, e.g. provisions and capital gains deferred on the occasion of a merger or other reorganization.

A corporate income tax declaration is due within 30 days of the approval by the shareholders of a legal liquidation by a liquidator (Art. 201(1) CGI).

At the end of the liquidation period, the liquidator files a tax return reporting the final results of the liquidation. If the total taxable income exceeds income already taxed in the fiscal years within the liquidation period (i.e. if the year of liquidation yields taxable income), the difference between the income previously taxed and total income for the

³² Art. L. 225-97 of the Code of Commerce

entire liquidation period is taxable. Conversely, if total income for the entire liquidation period is less than income already so taxed, a credit is allowed.

All previously untaxed income becomes taxable and deferred depreciation and loss carry-overs outstanding are offset against taxable income. Capital gains and losses are calculated and balanced under the normal rules.

Long-term capital gains on qualifying assets (i.e. mainly participation shares) realized upon the liquidation of a company are subject to tax at the reduced rate. They need not be booked into the special long-term capital gains reserve. Their distribution does not attract additional corporate tax that would normally apply.

The distribution of the amounts previously booked into the long-term capital gains reserve normally attracts additional corporate income tax (i.e. equal to the difference between the tax levied on the gains at the reduced rate and the standard corporate income tax rate). However, if the distribution occurs after the dissolution of the company, no additional corporate income tax is due.

- c) Does it make a difference whether or not a permanent establishments of SE B remains in Member State A?

If the transfer of registered seat is treated as a winding-up of the company, the ownership of the assets and liabilities remaining in France (i.e. permanent establishment of SE B) is deemed to have changed, which entails the taxation of accrued capital gains.

- d) If after the transfer of the registered office, SE B will have a permanent establishment in Member State A, can SE B take over the provisions and reserves which are partly or wholly exempt from tax with the same roll-over relief?

If the transfer of the registered seat is treated as a winding-up of the company, the ownership of the assets and liabilities remaining in France (i.e. permanent establishment of SE B) is deemed to have changed. In this respect, provisions and reserves are recaptured and added to taxable income.

- e) If after the transfer of the registered office, SE B will have a permanent establishment in Member State A, can SE B's permanent establishment in Member State A take over the losses of SE A that have not been exhausted for tax purposes?

Operating losses incurred before the decision of liquidation may be carried forward during the liquidation period, subject to the limitations under the general rules (Art. 209 CGI). However, the losses arising during the liquidation period may be carried forward and set off against positive income of any subsequent financial year of the liquidation period or against final liquidation results. No limitation applies to the loss carry-forward during the liquidation period, even if such period exceeds 5 years. Loss carry-back is, however, disallowed.

Nevertheless, if the transfer of registered seat is treated as a winding-up of the company, the ownership of the assets and liabilities remaining in France (i.e. permanent establishment of SE B) is deemed to have changed. In this respect, no losses may be transferred.

Tax effects of the transfer for SH

- f) What are the tax effects for SH in case the transfer results in a winding up of SE for tax purposes?

The liquidation surplus, less registration taxes, is generally taxable to shareholders under the rules which govern dividends. However, the liquidation surplus is exempt from the précompte (equalization tax) and, correspondingly, does not entitle the recipient shareholder to the avoir fiscal. The tax on capital gains may also be significant.

Liquidation surplus (boni de liquidation) is defined as the difference between net assets (for tax purposes) and contributed capital which has not been reimbursed prior to liquidation. There are detailed rules on contributed capital concerning share premiums, prior reductions of capital, incorporation of reserves, prior merger effect, etc. The shareholders, individual or corporate, are exempt from income tax or corporate income tax up to the amount of contributed capital.

- g) Is the answer to 1f) different if:

- i) SH is a corporate shareholder?

Subject to certain conditions, all capital gains realized on business assets upon the liquidation of the company are deemed long-term gains and are, therefore, subject to tax at the reduced rate (i.e. 19 % for corporate shareholders), regardless of the date of acquisition of such assets (Art. 239bis B CBI). The same rule applies to the liquidation of a branch of a foreign company. Foreign shareholders also bear withholding tax on the liquidation surplus.

Independently from the taxation of the liquidation surplus, a corporate shareholder may, in certain cases, realize capital gains or losses as a result of a liquidation. If the shares have a book value exceeding the amount of the liquidation distribution, a capital loss results. If the book value is less than the nominal value or amount of liquidation distribution, a capital gain is recognized. For a non-resident, such gains and losses normally do not fall within the French tax jurisdiction.

- ii) SH is an individual shareholder?

If the acquisition price of the shares was higher than the contributed capital, the taxable amount is equal to the difference between the net assets and the higher acquisition price (Art. 161 CGI). Individual shareholders may elect for income spreading if the taxable liquidation surplus exceeds the average taxable income of the 3 preceding years (Art. 163 CGI).

The distribution of such gains to individual shareholders as well as the amounts previously booked into reserves is subject to tax at the flat rate of 15% in full satisfaction of the individual income tax liability (see special rules on lump-sum taxation).

Special rules on lump-sum taxation

These rules are applicable only on prior authorization of the Ministry of Economy and Finance and are aimed at those liquidations, which will contribute to healthy production and market in conformity with the Economic Plan. The authorization may apply to the transformation of legal form resulting in a new tax status (e.g. corporation to partnership) or to sales of shares of a company resulting in voluntary dissolution (e.g. reorganization within a group). They may apply to a change of legal seat.

The special rules bring about the following variations from the normal rules:

- (1) net capital gains realized on the liquidation of business assets are subject to tax at the reduced rate, regardless of the period for which the assets are held;*
- (2) the distribution of the capital gains and accumulated reserves is subject to tax at the flat rate of 15%. The tax is final for individual shareholders, whether or not resident in France. For corporate shareholders, the tax is credited against corporate income tax liability, or against the précompte, if the recipient is a parent company;*
- (3) distributions which are subject to flat-rate taxation do not entitle the recipient shareholder to the avoir fiscal tax credit. Correspondingly, the distribution is exempt from the précompte.*

For foreign shareholders, the special tax replaces normal dividend withholding tax on the surplus. However, any amounts not subject to the special tax will be subject to a withholding tax at standard domestic rate or the reduced tax treaty rate.

- h) Are there any effects for tax purposes if the transfer of the registered office is not considered as a winding up for tax purposes?

If the transfer of the registered office was not considered a winding-up for tax purpose, no tax consequences would arise provided all the assets and liabilities from SE A remain attached to a permanent establishment in Member State A.

Nevertheless, after the restructuring, SH A holds shares in SE B in Member State B instead of shares in SE A in Member State A. This situation may have some tax consequences on the allocation of the taxing right upon disposal of the shares. In this respect, France may not be willing to lose its taxing right over the shares and impose some requirements.

- i) Is the answer to 1h) different if:

- i) SH is a corporate shareholder?

France keeps its taxing right. Resident legal persons are taxable with respect to gains derived from shares in non-resident companies (SE B). However, under treaty provisions, a resident French corporate shareholder is often taxable exclusively in the other state (Member State B) on alienation of a substantial participation in a company of that other

state. If the gains remain taxable in France after the transfer of registered seat, SH A will benefit from roll-over relief, provided SH A is a stock company.

ii) SH is an individual shareholder?

Subject to treaty provisions, French-resident individuals are taxed on gains from shares in non-resident companies in the same way as on gains from shares in resident companies.

iii) SH is an individual

France may lose its taxing right. The situation may occur when SH A, which held a non-substantial participation in SE A, holds after the transformation a substantial participation in SE B and the relevant tax treaty allocates the taxing right of substantial participation exclusively to the country of residence of the company whose shares are alienated.

iv) SH is an individual owning a substantial interest

France may keep its taxing right. However, under treaty provisions, a resident French corporate shareholder is often taxable exclusively in the other state (Member State B) on alienation of a substantial participation in a company of that other state. If the gains remain taxable in France after the transfer of registered seat, SH A will benefit from roll-over relief, provided SH A is a stock company.

2) Assume Member State B is your country

Tax effects of the transfer for SE

A transfer to France of the registered office of a foreign company is treated as a formation of a company in France, involving all the tax consequences of a formation of a new company.

- a) If SE is considered to be a new company, how should the assets and liabilities of SE be valued?

Assets and liabilities would be valued at their real market value.

Tax effects of the transfer for SH

- b) Are there any tax effects for SH in case the transfer results in a formation of a new SE in your country? For example, with regard to the valuation of the shares in SE B?

No.

Bibliography

Regulations

- Council Regulation (EC) No 2157/2001 of 8 October 2001 on the Statute for a European company (SE)
- Council Directive 90/434/EEC of 23 July 1990
- French Finance law 2002 (Law no 2001-1275, 28 December 2001)
- Guideline of 25 October 2002 (BOI 4 I-2-02) on the application of the favourable regime
- Guideline of 21 August (BOI 13 D-2-02) on the transfer of losses

Books

Edition Francis Lefebvre- 1 December 2001- Jean-Yves Mercier- “La pratique des restructurations”.

IBFD, EC corporate tax law December 2002, Yves Long and Ambroise Bricet. France: Part A: Merger Directive

Report

IBFD report, 1995: the implementation of the EC Directive.

Articles

- Droit Fiscal, No 27 (2002) page 991-999. Patrick Dibout. « *Le régime fiscal français des fusions et opérations assimilées sous la lumière de la directive du 23 juillet 1990* ».
- Droit Fiscal, No 1-2 (2002) page 7-24. « Aménagements des régimes spéciaux prévus en faveur des restructurations d’entreprises ».

